

APPROVAL SHEET

承认书

Customer 客户名称	
Part NO. 产品型号	T7S131B-B1
Product type 产品内容	Mode: Transmissive type .Normally Black. TFT LCD Module LCD Module: Graphic 1024RGB*600Dot-matrix
Remarks 备注栏	<input type="checkbox"/> APPROVAL FOR SEPCIFICATIONS ONLY <input checked="" type="checkbox"/> APPROVAL FOR SEPCIFICATIONS AND SAMPLE
Signature by Customer: 客户确认签章	

Issued by	Checked by	Approved by

1. PHYSICAL DATA

Item	Contents	Unit
LCD type	TFT TRANSMISSIVE	---
Viewing direction	All	o'clock
Module size (W×H×T)	165 × 100 × 3.5	mm ³
Active area(W×H)	154.2144×85.92	mm ²
Number of dots(W×H)	1024(RGB) × 600	dots
Pixel Pitch(W×H)	0.1506×0.1432	mm
Driver IC	EK79007	---
Colors	16.7M	---
Backlight Type	27 white leds 9.6V /180mA	---
Interface Type	MIPI	---

2. Mechanical Dimension

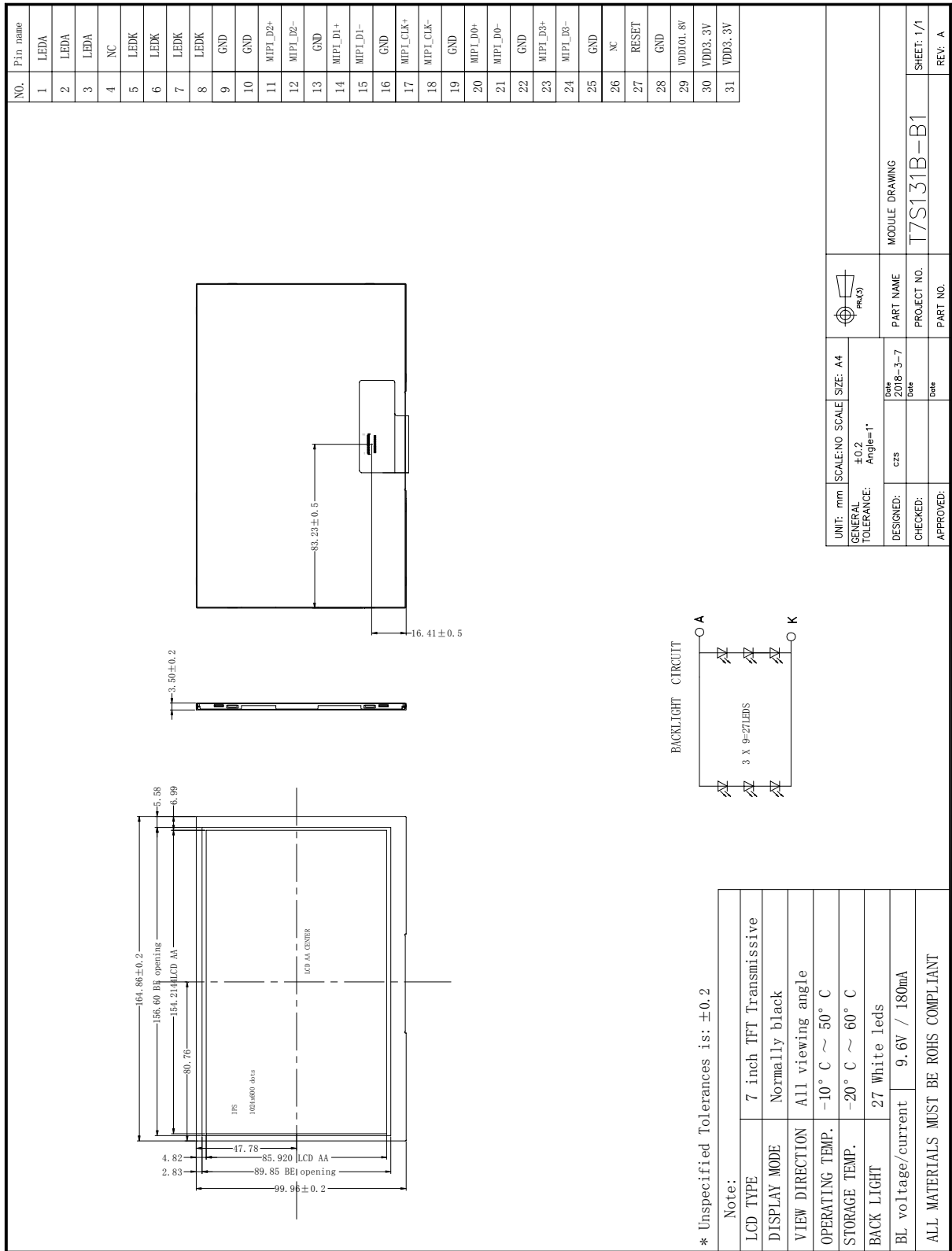

UNIT: mm	SCALE: NO SCALE	SIZE: A4
GENERAL TOLERANCE:	±0.2	Angle=1°
DESIGNED:	cts	Date: 2018-3-7
CHECKED:		Date:
APPROVED:		Date:
PART NAME: MODULE DRAWING		
PROJECT NO: T7S131B-B1		
PART NO:		
		SHEET: 1/1
		REV: A

3. Pin Descriptions

Pin No.	Symbol	Functional	Notes
1-3	LEDA	Back light LED Anode (+)	
4	NC	No connection	
5-8	LEDK	Back light LED Cathode(-)	
9-10	GND	Ground	
11	MIPI_D2+	+MIPI differential data input	
12	MIPI_D2-	- MIPI differential data input	
13	GND	Ground	
14	MIPI_D1+	+ MIPI differential data input	
15	MIPI_D1-	- MIPI differential data input	
16	GND	Ground	
17	MIPI_CLK+	+ MIPI differential clock input	
18	MIPI_CLK-	- MIPI differential clock input	
19	GND	Ground	
20	MIPI_D0+	+ MIPI differential data input	
21	MIPI_D0-	- MIPI differential data input	
22	GND	Ground	
23	MIPI_D3+	+ MIPI differential data input	
24	MIPI_D3-	- MIPI differential data input	
25	GND	Ground	
26	NC	No connection	
27	RESET	Global reset pin	
28	GND	Ground	
29	VDDIO1.8V	Power 1.8V	
30-31	VDD3.3V	Power Supply 3.3V	

4. ABSOLUTE MAXIMUM RATINGS

(GND=AGND=0V)

Parameter	Symbol	Min	Max	Unit
Power supply1	V _{DD}	-0.5	+3.96	V
Power supply2	Avdd	-0.5	+13.8	V
Operating temperature	T _{OPR}	-10	50	°C
Storage temperature	T _{STG}	-20	60	°C

Input voltage for BOE LCD at temperature 25°C

5. DC ELECTRICAL CHARACTERISTICS

Parameter	Symbol	Condition	Min.	Typ.	Max.	Unit
Low level input voltage	Vil	For the digital circuit	0	-	0.3×VDD	V
High level input voltage	Vih	For the digital circuit	0.7×VDD	-	VDD	V
Input leakage current	Ii	For the digital circuit	-	-	±1	µA
High level output voltage	Voh	Ioh= -400 µA	VDD-0.4	-	-	V
Low level output voltage	Vol	Iol= +400 µA	-	-	GND+0.4	V
Pull low/high resistor	Ri	For the digital input pin @ VDD=3.3V	200K	250K	300K	ohm
Digital Operation current	Idd	Fclk=65 MHz, FLD=50KHz, VDD=3.3V	-	15	25	mA
Digital Stand-by current	Ist1	Clock and all functions are stopped	-	10	50	µA
Analog Operating Current	Idda	No load, Fclk=65MHz, FLD=50KHz @ AVDD=10V, V1=8V, V14=0.4V	-	10	12	mA
Analog Stand-by current	Ist2	No load, Clock and all functions are Stopped	-	10	50	µA
Input level of V1 ~ V7	Vref1	Gamma correction voltage input	0.4×AVDD	-	AVDD-0.1	V
Input level of V8 ~ V14	Vref2	Gamma correction voltage input	0.1	-	0.6×AVDD	V
Output Voltage deviation	Vod1	Vo = AVSS+0.1V ~ AVSS+0.5V and Vo = AVDD-0.5V ~ AVDD-0.1V	-	±20	±35	mV
Output Voltage deviation	Vod2	Vo = AVSS+0.5V ~ AVDD-0.5V	-	±15	±20	mV
Output Voltage Offset between Chips	Voc	Vo = AVSS+0.5V ~ AVDD-0.5V	-	-	±20	mV
Dynamic Range of Output	Vdr	SO1 ~ SO1536	0.1	-	AVDD-0.1	V
Sinking Current of Outputs	IOLy	SO1 ~ SO1536; Vo=0.1V v.s 1.0V, AVDD=13.5V	80	-	-	uA
Driving Current of Outputs	IOHy	SO1 ~ SO1536; Vo=13.4V v.s 12.5V, AVDD=13.5V	80	-	-	uA
Resistance of Gamma Table	Rg	Rn: Internal gamma resistor	0.7×Rn	1.0×Rn	1.3×Rn	ohm

6. AC ELECTRICAL CHARACTERISTICS

(TA = -20 to 85°C, VDD = 2.3 to 3.6V, AVDD = 8 to 13.5V, GND = AGND = 0V)

TTL mode

Parameter	Symbol	Condition	Min.	Typ.	Max.	Unit
VDD Power On Slew rate	TPOR	From 0V to 90% VDD	1	-	20	ms
RST pulse width	TRST	DCLK = 65MHz	50	-	-	us
DCLK cycle time	Tcph	-	14	-	-	ns
DCLK pulse duty	Tcwh	-	40	50	60	%
VSD setup time	Tvst	-	5	-	-	ns
VSD hold time	Tvhd	-	5	-	-	ns
HSD setup time	Thst	-	5	-	-	ns
HSD hold time	Thhd	-	5	-	-	ns
Data set-up time	Tdsu	D0[7:0], D1[7:0], D2[7:0] to DCLK	5	-	-	ns
Data hold time	Tdhd	D0[7:0], D1[7:0], D2[7:0] to DCLK	5	-	-	ns
DE setup time	Tesu	-	5	-	-	ns
DE hold time	Tehd	-	5	-	-	ns
Output stable time	Tsst	10% to 90% target voltage. CL=90pF R=10K ohm(Cascade)	-	-	6	us
		Dual gate			3	

7. Data input format

Vertical input timing

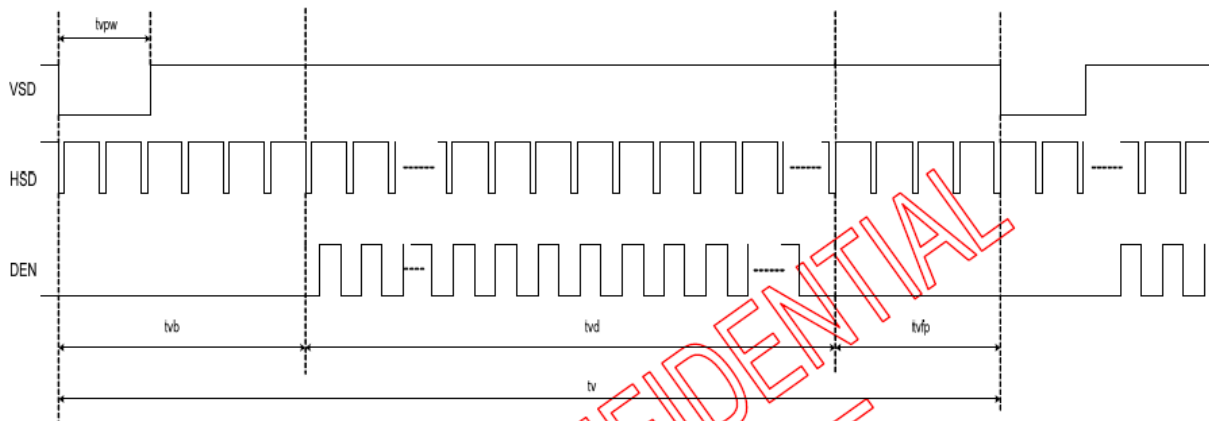

Vertical input timing

Horizontal input timing

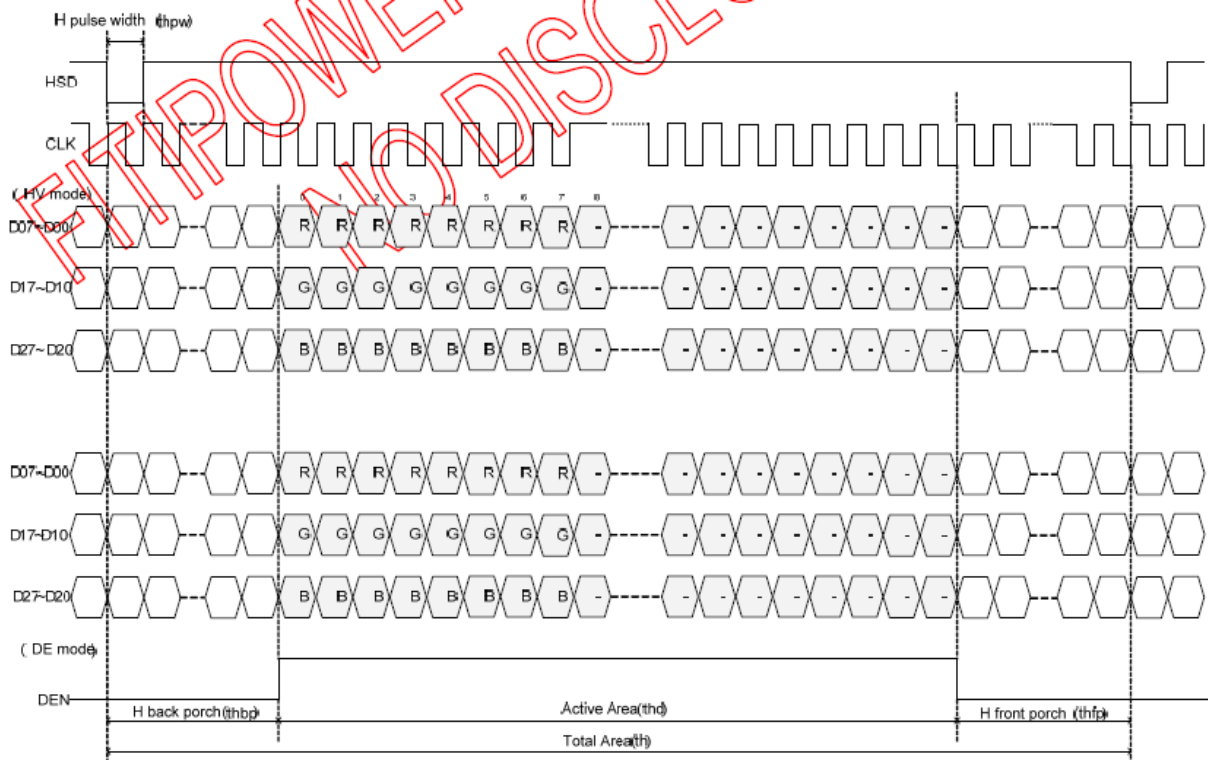

Horizontal input timing

DE mode

Parameter	Symbol	Value			Unit
		Min.	Typ.	Max.	
DCLK frequency @Frame rate=60hz	fclk	40.8	51.2	67.2	Mhz
Horizontal display area	thd	1024			DCLK
HSYNC period time	th	1114	1344	1400	DCLK
HSYNC blanking	thb+thfp	90	320	378	DCLK
Vertical display area	tvd	600			H
VSYNC period time	tv	610	635	800	H
VSYNC blanking	tvb+tvfp	10	35	200	H

HV mode(1)

HV mode Horizontal input timing					
Parameter	Symbol	Value			Unit
Horizontal display area	thd	1024			DCLK
DCLK frequency@ Frame rate=60hz	fclk	Min.	Typ.	Max.	Mhz
		44.9	51.2	63	
1 Horizontal Line	th	1200	1344	1400	DCLK
HSYNC pulse width	thpw	Min.	1		
		Typ.	-		
		Max.	140		
HSYNC back porch	thbp	160	160	160	
HSYNC front porch	thfp	16	160	216	

HV mode(2)

Vertical input timing					
Parameter	Symbol	Value			Unit
		Min.	Typ.	Max.	
Vertical display area	tvd	600			H
VSYNC period time	tv	624	635	750	H
VSYNC pulse width	tvpw	1	-	20	H
VSYNC back porch	tvb	23	23	23	H
VSYNC front porch	tvfp	1	12	127	H

8. Backlight Characteristic

Item	Symbol	Min	Typical	Max	Unit
LED module Forward voltage	V_{LED}	--	9.6	--	V
LED module current	I_{LED}	--	180	--	mA
L/G Surface Luminance ★1	L_S	250	300	--	mcd
LCM Surface brightness uniform ★2	L_D	80	--	--	%

★ 1 Test condition is:

- (a) Center point on active area.
- (b) Best Contrast.

★2 Uniform measure condition:

- (1) Measure 9 point. Measure location show below;
- (2) Uniform = (Min. brightness / Max. brightness) * 100%
- (3) Best Contrast.

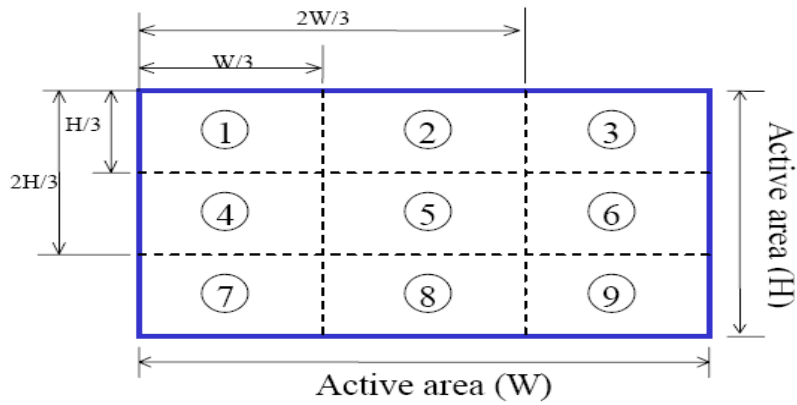

9. Electro-optical Characteristics

Parameter		Symbol	Condition	Min.	Typ.	Max	Unit	Remark
Viewing angle range	Hor.	$\phi 3$	$CR \geq 10$	80	85		Deg.	Note 2
		$\phi 9$		80	85		Deg.	
	Ver.	$\theta 12$		80	85		Deg.	
		$\theta 6$		80	85		Deg.	
Color gamut(C light)				50		%		
Luminance Contrast ratio		T(%)	$\phi 0^\circ$	600	800			Note 3
Response Time		T _{RT}	Temp=25° C		25	40	ms	Note 1

.Note1.Definition of Optical Response Time:

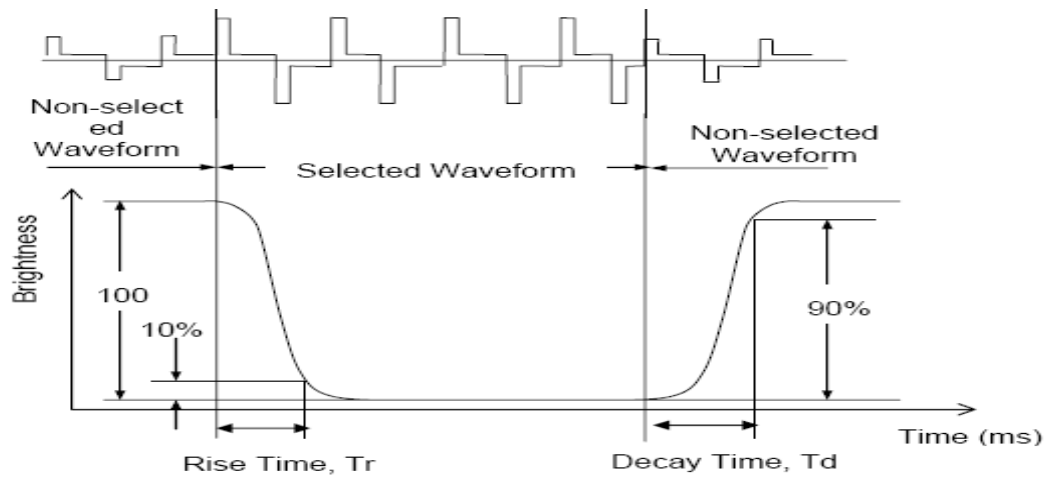

.Note2.Definition of Viewing Angle θ and ϕ :

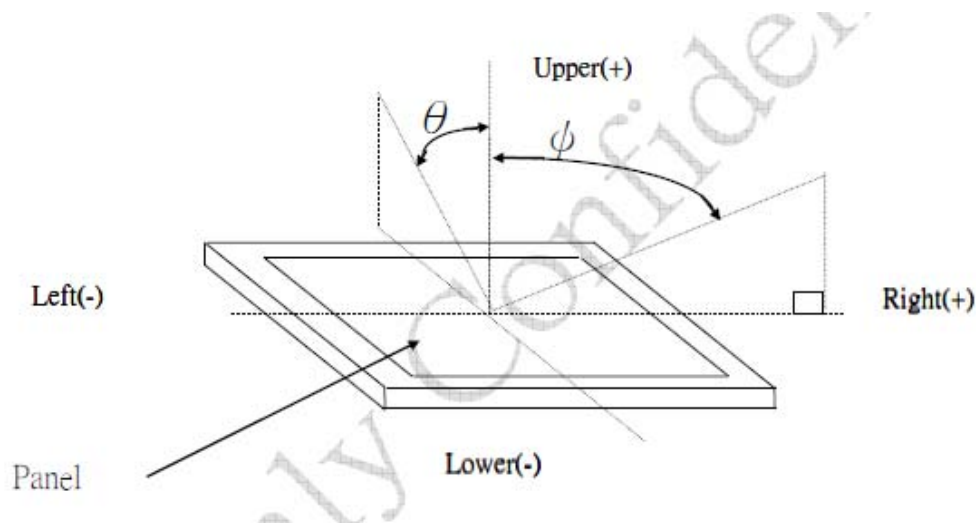

Note3.Definition of Contrast ratio (CR):

$$CR = \frac{\text{Brightness of Non-selected Segment (B2)}}{\text{Brightness of Selected Segment (B1)}}$$

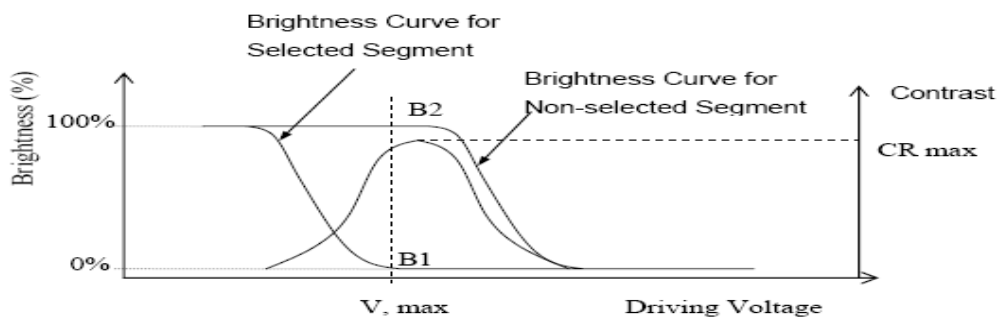

10. Reliability

10.1 Mtbf

The LCD module shall be designed to meet a minimum MTBF value of 50000 hours with normal

10.2 Test condition

NO.	ITEM	CONDITION	CRITERION
1	High Temperature Non-Operating Test	60°C*240Hrs	<ul style="list-style-type: none"> ◦ No Defect Of Operational Function In Room Temperature Are Allowable ◦ IDD of LCM in Pre-and Post-Test Should Follow Specification
2	Low Temperature Non-Operating Test	-20°C*240Hrs	
3	High Temperature/Humidity Non Operating Test	60°C*90%RH*240Hrs	
4	High Temperature Operating Test	50°C*240Hrs	
5	Low Temperature Operating Test	-10°C*240Hrs	
6	Thermal Shock Test	-10°C (30Min) - 50°C (30Min) *10CYCLES	

Notes:

1. Judgments should be made after exposure in room temperature for two hours.
2. The distill water is used for the high temperature/humidity test.
3. The sample above is individually for every reliability tests condition.

11. Inspection standards

1.AQL(Acceptable Quality Level

AQL of major and minor defect.

	MAJOR DEFECT	MINOR DEFECT
AQL	0.65	1.5

2. Basic conditions for inspection

The LCM face to us, in normal environment, the lux is 1000 ± 200 . (Darkroom's lux: 100 ± 50), About an angle of incidence 30° , a distance of 30 cm with an angle of $45 \pm 10^\circ$ to check the products without uncovering the film!

(As shown below)

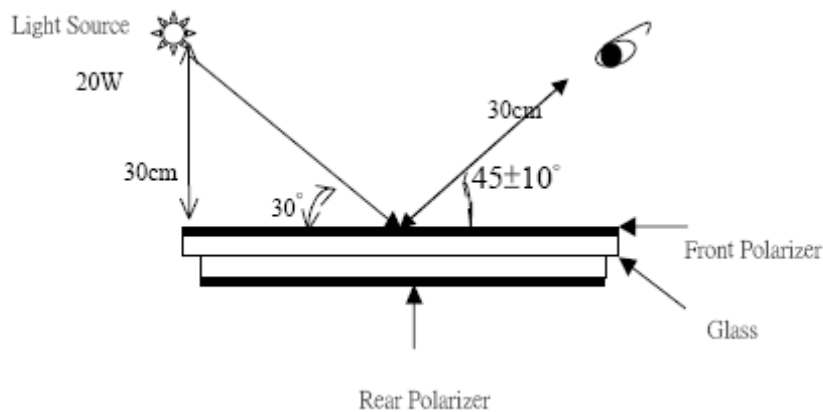

12. Precautions for using LCD modules.

12.1 Safety

- (1) Do not swallow any liquid crystal, even if there is no proof that liquid crystal is poisonous.
- (2) If the LCD panel breaks, be careful not to get liquid crystal to touch your skin.
- (3) If skin is exposed to liquid crystal, wash the area thoroughly with alcohol or soap.

12.2 Storage Conditions

- (4) Store the panel or module in a dark place where the temperature is $23 \pm 5^\circ\text{C}$ and the humidity is below $45 \pm 20\% \text{RH}$.
- (5) Store in anti-static electricity container.

(6) Store in clean environment, free from dust, active gas, and solvent.

(7) Do not place the module near organics solvents or corrosive gases.

(8) Do not crush, shake, or jolt the module.

12.3 Handling Precautions

(9) Avoid static electricity, which can damage the CMOS LSI.

(10) The polarizing plate of the display is very fragile, please handle it very carefully.

(11) Do not give external shock.

(12) Do not apply excessive force on the surface.

(13) Do not wipe the polarizing plate with a dry cloth, as it may easily scratch the surface of plate.

(14) Do not use ketonic solvent & Aromatic solvent, use with a soft cloth soaked with a cleaning naphtha solvent.

(15) Do not operate it above the absolute maximum rating.

(16) Do not remove the panel or frame from the module.

12.4 Warranty

The period is within twelve months since the date of shipping out under normal using and storage conditions.